



MODEL A270
INFRARED PATIO HEATER

The Original Outdoor Patio Heater

Manufactured by

INFRARED DYNAMICS, INC.

Yorba Linda, CA 92886 U.S.A.

Tel: (714) 572-4050 Fax: (714) 572-6093

Toll-Free: (888) 317-5255

www.infradyne.com

! WARNING FOR OUTDOOR USE ONLY!

SPECIFICATIONS:

Completely Self-contained
Rain Protected
Wind Resistant
No Electrical Required

100% Safety Shutoff Control
40,000 BTUH Input Rating
Constant Pilot
Propane Gas

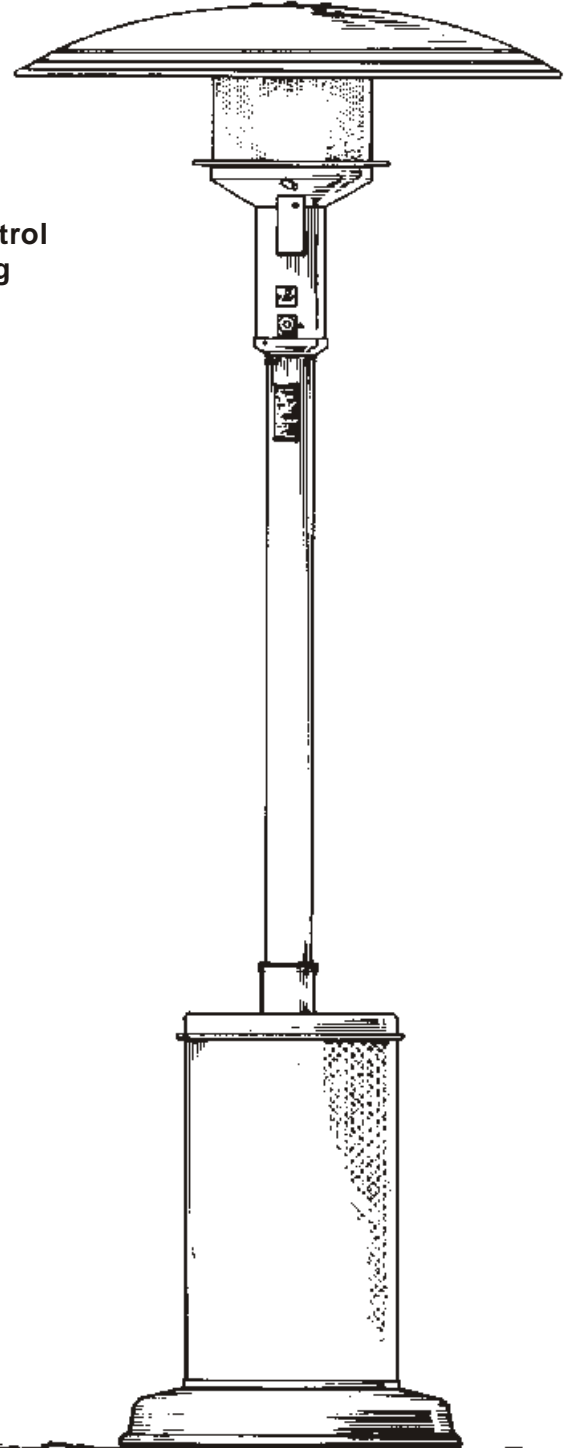

! DANGER

If you smell gas:

1. Shut off gas to the appliance.
2. Extinguish any open flame.
3. If the odor continues, keep away from the appliance and immediately call your gas supplier or fire department.

! WARNING



Do not store or use gasoline or other flammable vapors and liquids in the vicinity of this or any other appliance. An LP Gas cylinder not connected for use shall not be stored in the vicinity of this or any other appliance.

! WARNING

Improper installation, adjustment, alteration, service or maintenance can cause property damage, injury or death. Read the installation, operating and maintenance instructions thoroughly before installing or servicing this equipment.

TO THE INSTALLER: Leave this manual with the owner after installation.

TO THE OWNER: Keep this manual in a safe place in order to provide your serviceman with the necessary information for future reference.



PROP. 65 WARNING!!! If not installed, operated and maintained in accordance with manufacturer's instructions, this product could expose you to substances in the fuel or from combustion, including Carbon Monoxide, which can cause death or serious illness, and which are known to the State of California to cause cancer, birth defects or reproductive harm.

Installation, Operation and Maintenance Instructions for the Sunglo Model A270 Gas-fired Patio Heater

INSTALLATION

Important Safety Rules:

1. Children and adults should be alert to high surface temperature of areas above the post when operating this heater.
2. Children should be carefully supervised when they are in the area of the heater.
3. **NEVER** hang anything including clothes or other flammable items on the heater.
4. **DO NOT** operate this heater unless it is fully assembled with reflector in place.
5. Installation and repair should be done by a qualified service person. The heater should be inspected before use and at least annually by a qualified service person. More frequent cleaning may be required as necessary. It is imperative that control compartment, burners and circulating air passages of the heater be kept clean.

Prior to assembling your Model A270 propane heater, the following must be reviewed. Compliance with the following should yield satisfactory heater operation. These instructions should be retained for future reference. The installation must conform with local codes or local authority having jurisdictions.

1. The Model A270 gas-fired infrared patio heater is intended for heating residential and non residential areas. When the appliance is connected to a fixed piping system, the installation must conform with local codes or, in the absence of local codes, with the National Fuel Gas Code, ANSI Z223.2/NFPA 54, Natural Gas and Propane Installation Code, CSA B149.1 or Propane Storage and Handling Code, B149.2.
2. This Appliance shall be used only in a well-ventilated space and shall not be used in a building, garage or any other enclosed area. This appliance may be installed in a shelter no more inclusive than:
 - a. With walls on all sides but no overhead cover.
 - b. Within a partial enclosure which includes an overhead cover but no more than two side walls. These side walls may be parallel, as in a breezeway, or at right angles to each other.
 - c. Within a partial enclosure which includes an overhead cover and three side walls as long as 30% of the horizontal periphery is permanently open.

3. Proper clearance from combustible materials must be maintained at all times. The minimum clearances are as follows:

Minimum Clearance from Combustibles

Side	24" (61 cm)
Rear	24" (61 cm)
Ceiling	18" (46 cm)
Below	84" (84 cm)

Combustible materials are considered to be wood, compressed paper, plant fibers, plastic, Plexiglas or other materials capable of being ignited and burned. Such materials shall be considered combustible even though flame-proofed, fire-retardant treated or plastered. Additional clearance may be required for glass, painted surfaces and other materials which may be damaged by radiant or convection heat.

4. The purpose of the **Floor Clamp Kit** is to provide supplementary safety and stability for our portable heaters. Floor Clamp should be used to secure portable patio heaters to help prevent tip over. Floor Clamp Kits are provided with each heater. If for some reason the Floor Clamp Kit is missing it is available from the factory at no charge. For questions regarding the Floor Clamp Kit contact Infrared Dynamics, Inc. toll free at (888) 317-5255.
5. The gas manifold supply pressure must be regulated at 11" water column utilizing a U/L listed regulator. Any replacement regulator must be U/L listed. The minimum inlet pressure to the regulator from the tank is 5 PSI and maximum pressure is 150 PSI.
6. The heater must be inspected before each use, and at least annually by a qualified service person.
 - a. The appliance area must be kept clear and free of combustible materials, gasoline and other flammable vapors and liquids.
 - b. Gas jets and burner must be kept clear of dirt and cobwebs. Flow of combustion and ventilation air through the perforated portions of the heater must not be obstructed.
 - c. All gas connections should be checked for leaks utilizing a soap solution. Never use a flame for this purpose.
 - d. The flame pattern at the emitter grid should be visually checked whenever heater is operated (see figure 1.). If flames extend more than 1/2 inch beyond surface of the emitter grid or black soot is accumulating on the emitter grid or reflector, the heater should be turned off immediately. The heater should not be operated again until repairs are made.
 - e. Any cleaning agent used on the heater should be of a non-combustible and non-corrosive nature.

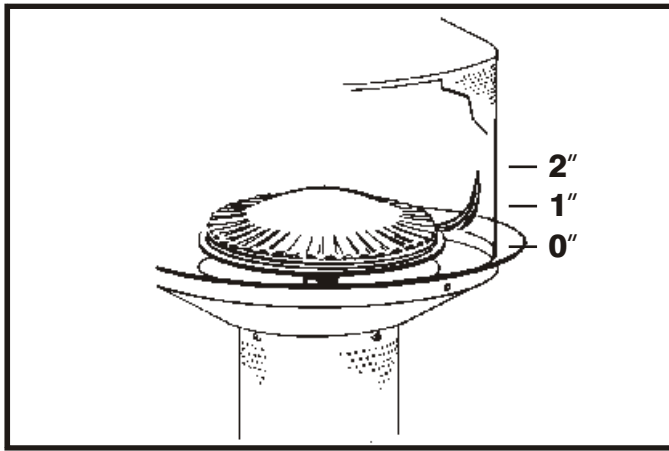

Figure 1. Normal Flame Position

- f. The stainless steel emitter grid normally does not require cleaning and should **NEVER** be painted. The reflector may be cleaned, but never painted.
7. The hose assembly shall be properly located out of pathways where people may trip over it. The hose must be protected from contact with hot or sharp surfaces both during use and while in storage. The hose assembly shall be visually inspected prior to each used of the heater. If excessive abrasion or wear is evident, or the hose is cut, it must be replaced prior to operating the heater. The replacement hose regulator, Part #90017-4, may be obtained from manufacturer or sales representative. See parts list.
 8. **DO NOT** use any pressure regulator or hose assembly other than those supplied with the appliance. Replacement pressure regulator and hose assembly must be those specified by Infrared Dynamics. Replacement parts may be obtained from the manufacturer or your local sales representative.
 9. This appliance is designed to operate with a standard five (5) gallon propane tank. The propane cylinder must be:
 - a. Be constructed and marked in accordance with the specifications for LP-Gas cylinders of the U.S Department of Transportation (DOT); or the Standard for Cylinders, Spheres and Tubes for Transportaion of Dangerous Goods and Commission, CAN/CSA-B339, as applicable:
 - b. Provided with a listed overfilling device; and,
 - c. Provided with a cylinder connection device compatible with the connection for the appliance.
 10. Propane tank must be secured to the heater with protective chain provided. The cylinder must be positioned upright for proper vapor withdrawal. The cylinder must include a collar to protect cylinder valve.

The following precautions regarding propane tank must be observed:

- a. Do not store a spare LP-Gas cylinder under or near this appliance.
 - b. Never fill the cylinder beyond 80% full.
11. Tank connector fittings must be maintained in good condition. A leak test should be performed with soapy water whenever a new tank connection is made. **NEVER use a match to test for leaks.**
 12. Propane tank must be turned off whenever the heater is not in use. When the heater is to be stored indoors, the connection between the propane cylinder and the heater must be disconnected and stored in accordance with Chapter 5 of the Standard for Storage and Handling of Liquefied Gases, ANSI/NFPA 58.
 13. The A270 Sunglo Heater has been designed with several safety features. These include 100% safety shutoff control, elevated heating element, weighted base, and tank quick connect coupling. Any modification to the heater not described in the installation instructions may compromise the safety of this appliance. Of special concern is the following:
 - (1) DO NOT shorten post length;
 - (2) DO NOT bypass thermocouple safety;
 - (3) DO NOT operate heater without a reflector; and
 - (4) DO NOT remove filler from weighted base.
 Clothing or other flammable materials should not be hung from the heater, or placed on or near the heater. The area above the post may be extremely hot. Direct contact with these metal surfaces should be avoided in order to prevent burns or clothing ignition.

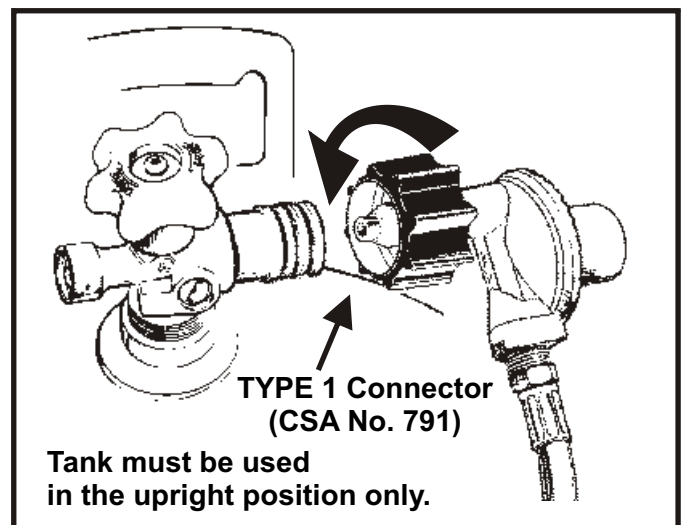
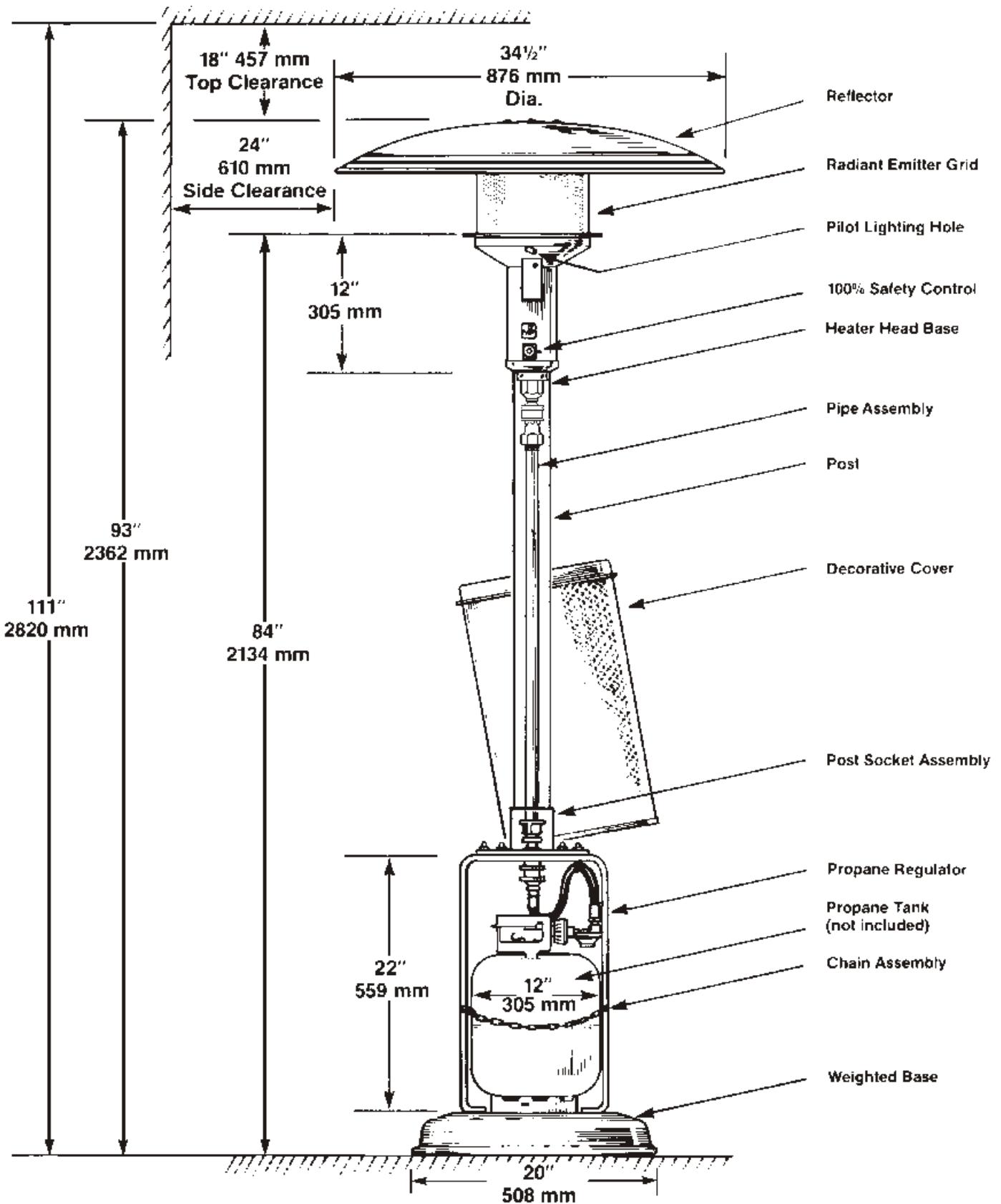

Figure 2. TYPE 1 Connector



HEATER ASSEMBLY MODEL A270

Insert heater head into quick connect fitting.

Pull down on quick connect sleeve to install heater head.

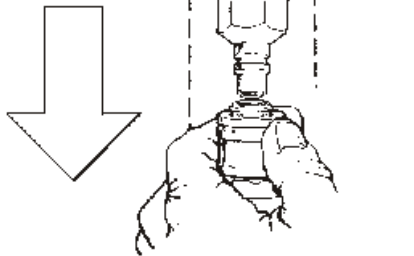

Step 1.

- Install the gas line by sliding back collar of quick disconnect coupling while inserting heater head as shown. Release collar to secure connection. Check to make sure connection is secure before proceeding.
- Slide Pipe Assembly with heater attached into the top end of the post and secure heater to post with the four screws provided.

NOTE: Post label should face front.

WARNING: Remove any dust cap or paper covering which may block the flow of gas.

Step 2.

- Secure "L" brackets to heater base with hex head bolts, spacer nuts, and lock washers provided.
- Secure socket assembly to "V" brackets as shown below using the square head bolts, lock washers, and acorn nuts provided.
- Install chain kit onto "L" bracket using holes provided.
- Slide Decorative cover down over post socket.

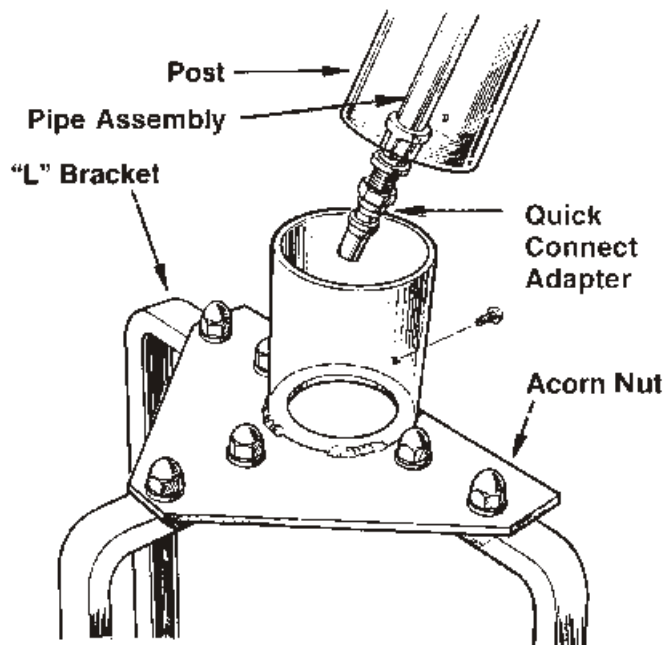
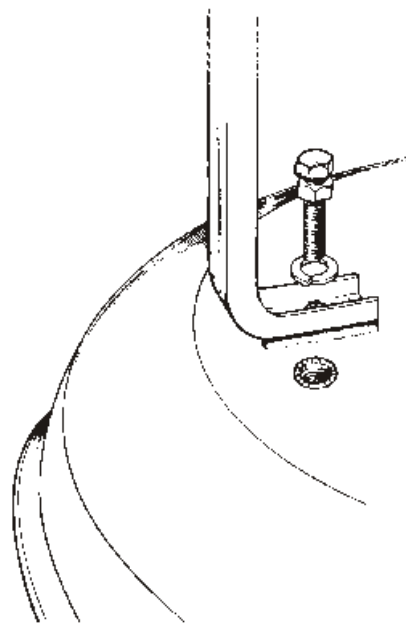

Step 3.

- Slide post down into socket with pipe extending through hole in the bottom of the socket.
- Slide Decorative cover up around post.
- Attach the hose to pipe assembly with the quick-connect adapter.
- Secure reflector to top of heater head. Use flat washer above and below reflector holes.
- Set tank into place and secure with safety chain.
- Connect regulator to tank.



Replacement Parts List

Item	Part No.	Description
1	70017	Nut, ¼ -20 Hex SS
2	70024	Washer, ¼ SAE SS
3	10261	Reflector, PH
4	70006	bolt, ¼ x ¾ Hex SS
5	70033	Washer, ¼ Inter SS
6	27006	Assy, PH Emitter Grid
7	70025-2	Clip, Stainless Steel
8	30225	Shield, PH Head
9	30202	Pan, PH Head
10	70005	Screw, #8 x ½ SP SS
11	30204-1	Cylinder, PH Perf (7000)
12	27007	Assy, PH Burner Pltd
13	70030	Clamp, 1"
14	35001-31	Orifice, #31 DS (Nat)
	35001-49	Orifice, #49 DS (Propane)
15	35012	Adapter, Orifice ⅜
16	90002-3	Control, 7000 MRLC Nat
	90003-3	Control, 7000 ERLC Nat-24V
	90004-3	Control, 7000 MLC-Propane
17	80005	Nipple, ½ x 2 ⅝ Blk
20	27018-1	Assy, PH H Base
	27018-2	Assy, 24V PH Head Base
21	90031	Thermocouple T46518
22	80031	Tubing, AL-¼ x 14L
23	90021	Pilot, Natural #27919
	90022	Pilot, Propane 327920
24	90015	Natural Pilot Orifice
	90016	Propane Pilot Orifice
25	30258	PH Pilot Shield
26	27025	Assy, 7000 Handle
27	30213	Channel, PH Pilot
28	70020	Screw, #10 x 1 ¼ SS
29	30299	Cover, PH Pilot Hole
30	80026	Tubing Fastener-¼"

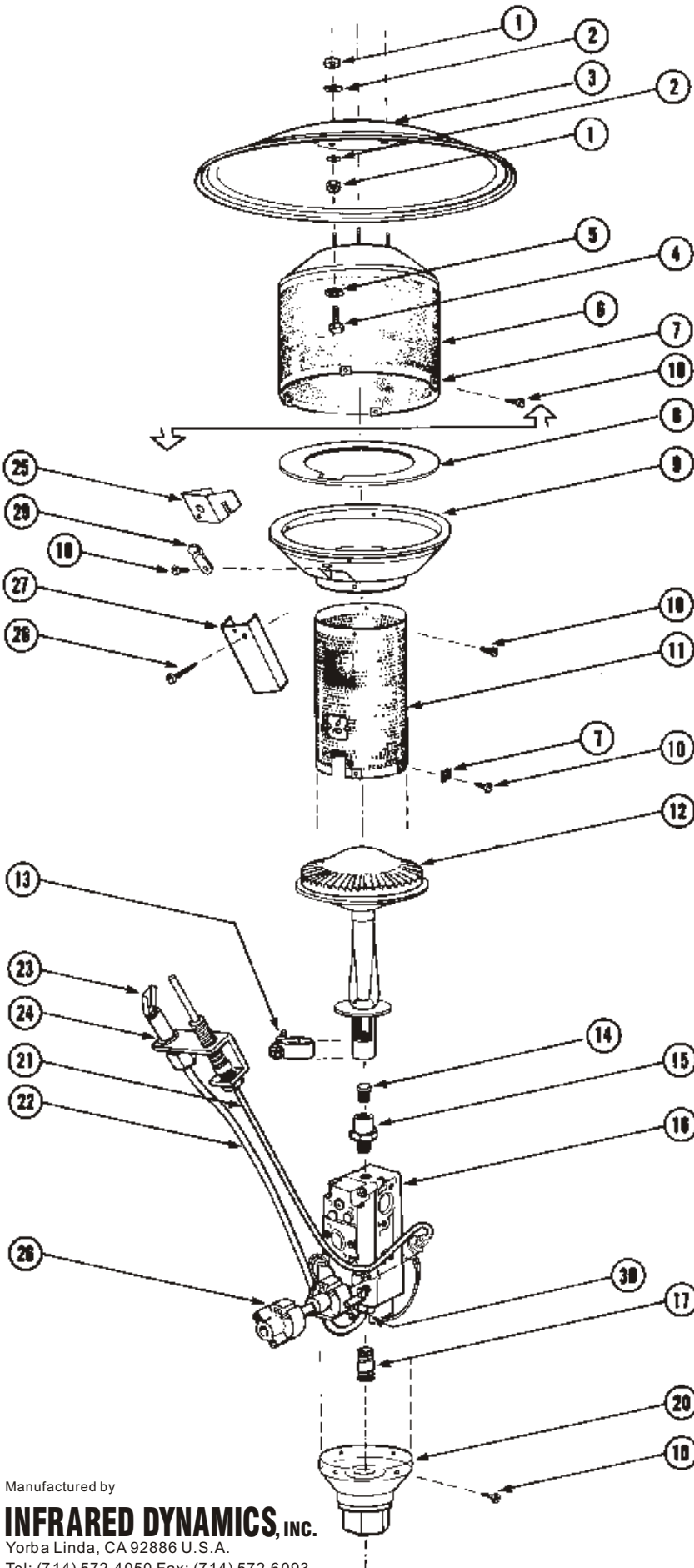

Manufactured by
INFRARED DYNAMICS, INC.
 Yorba Linda, CA 92886 U.S.A.
 Tel: (714) 572-4050 Fax: (714) 572-6093
 Toll-Free: (888) 317-5255
 www.infradyne.com

Base Parts List

Item	Part No.	Description
1	60008-1	Lighting Instructions
2	30280	Post, A270 - 45" L
3	80006-4	Pipe, 42" L, Black
4	70011	Nut, $\frac{3}{8}$ " Acorn
5	70013	Washer, $\frac{3}{8}$ Lock
6	70007	Bolt, $\frac{3}{8}$ x $\frac{3}{4}$ L-SQ
7	70028	Eyebolt, $\frac{3}{8}$ es2 w/Nut
8	70012	Bolt, $\frac{3}{8}$ -16 x 1 $\frac{1}{4}$ "
9	70059	Nut, $\frac{3}{8}$ "
10	10264-4	Assy, A270 Base Sun
11	300279-5	Univ "L" Bracket (24)
12	70029	Hook, 1 $\frac{1}{2}$ " S
13	70027	A270 Chain
14	27033	Assy, A270 Dec Cover
15	90017-4	Assy, Reg/Hose QCCI
16	27002-4	Assy, A270 Socket
17	80085	Reducer, $\frac{1}{2}$ " x $\frac{1}{4}$ "
18	90078	Adapter, #250
19	27020	Floor Clamp Kit
20	90081	Quick Connect-Male
21	90082	Quick Connect-Female

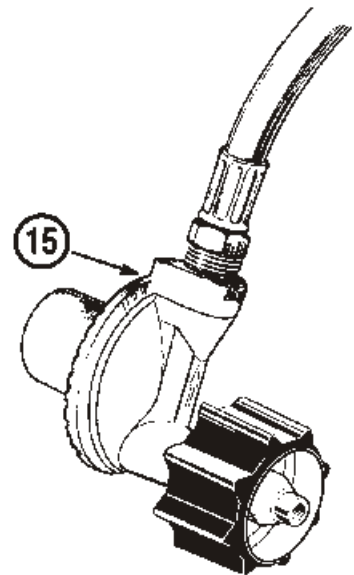
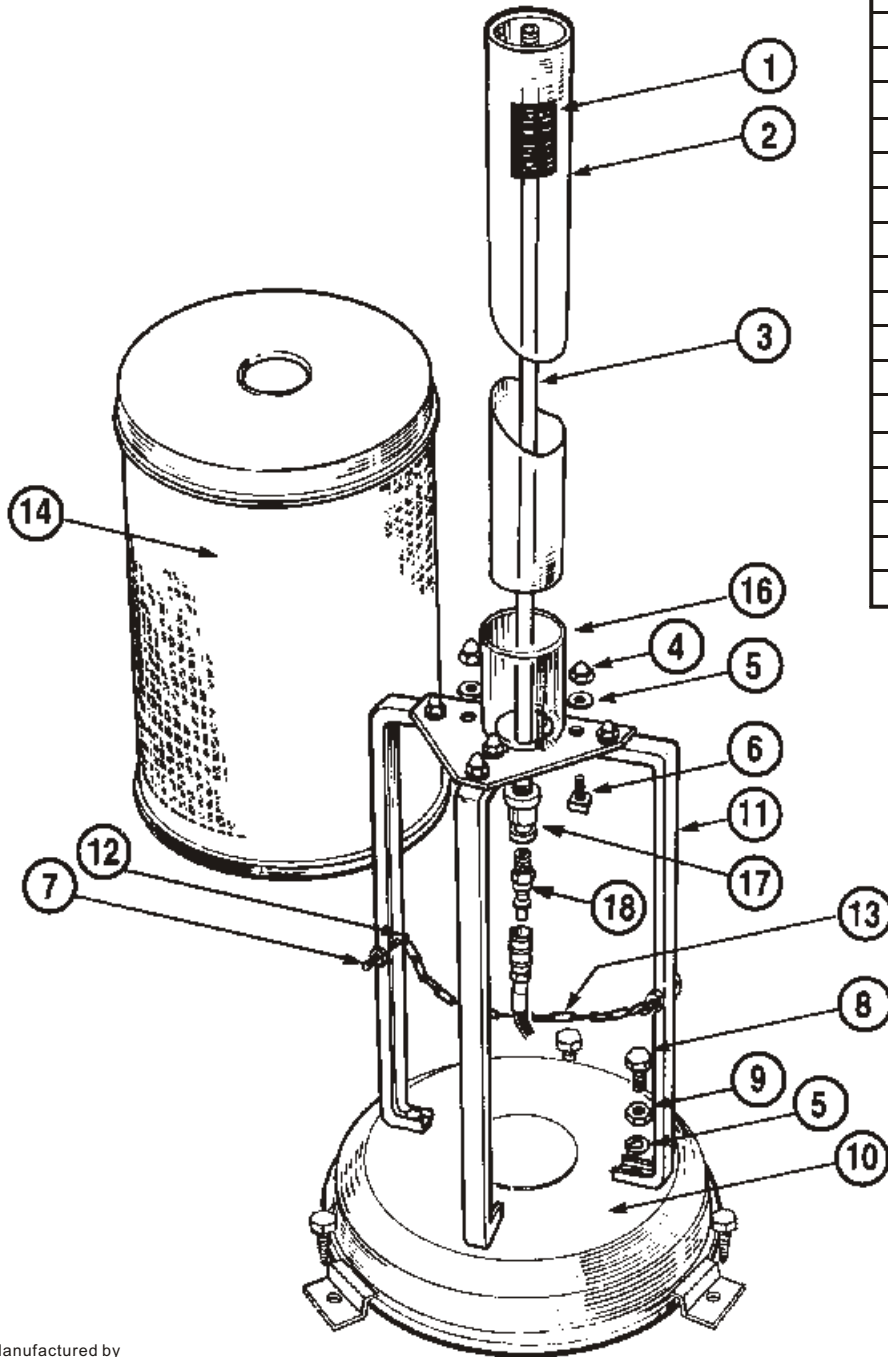

Manufactured by

INFRARED DYNAMICS, INC.

Yorba Linda, CA 92886 U.S.A.

Tel: (714) 572-4050 Fax: (714) 572-6093

Toll-Free: (888) 317-5255

www.infradyne.com

Optional Spark Ignition System

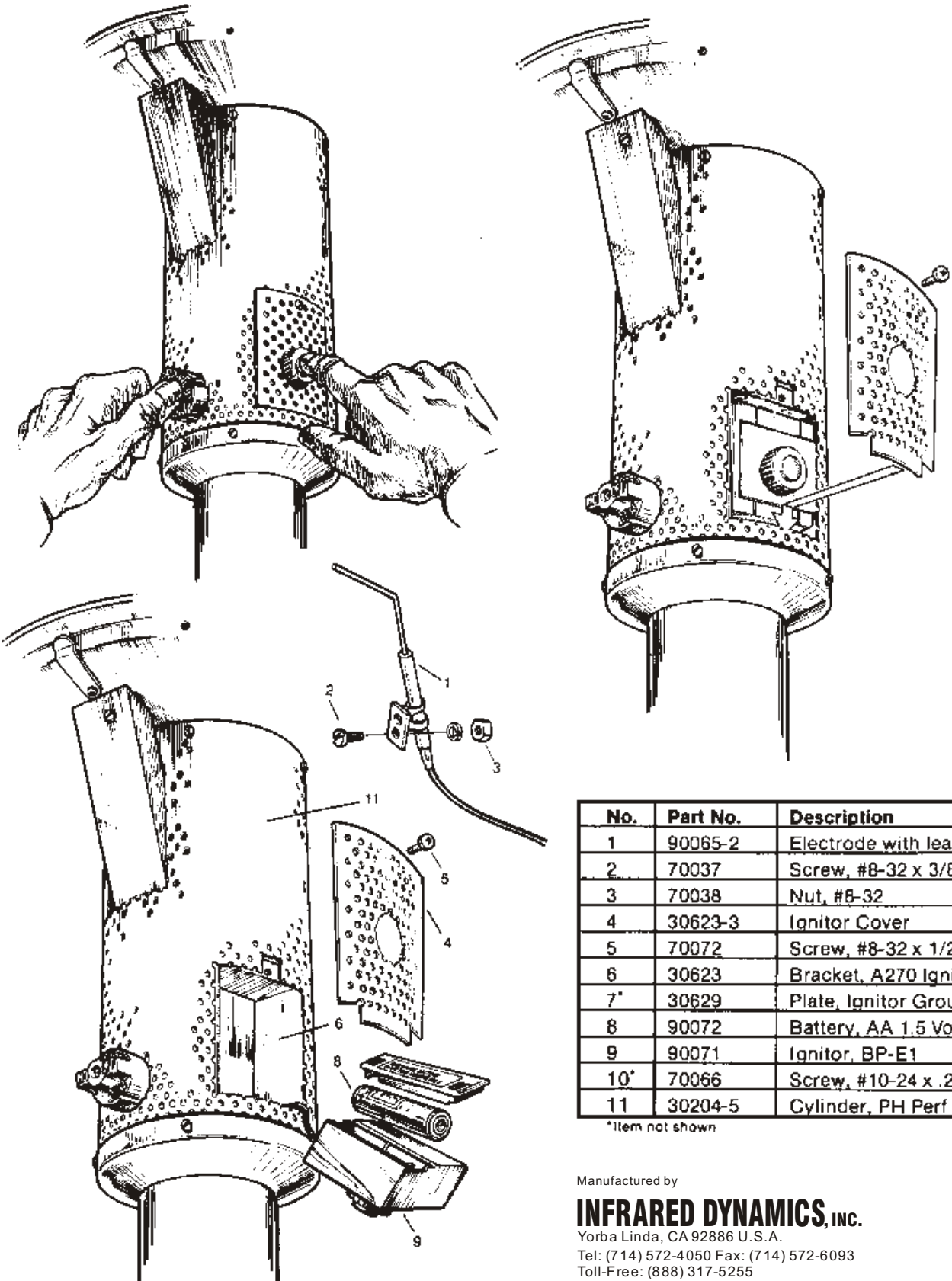

No.	Part No.	Description
1	90065-2	Electrode with lead
2	70037	Screw, #8-32 x 3/8
3	70038	Nut, #8-32
4	30623-3	Ignitor Cover
5	70072	Screw, #8-32 x 1/2 SS
6	30623	Bracket, A270 Ignitor
7*	30629	Plate, Ignitor Ground
8	90072	Battery, AA 1.5 Volt
9	90071	Ignitor, BP-E1
10*	70066	Screw, #10-24 x .250L
11	30204-5	Cylinder, PH Perf SS

*Item not shown

Manufactured by

INFRARED DYNAMICS, INC.

Yorba Linda, CA 92886 U.S.A.

Tel: (714) 572-4050 Fax: (714) 572-6093

Toll-Free: (888) 317-5255

www.infradyne.com

Propane Safety

⚠ WARNING

1. Only qualified persons are permitted to fill propane cylinder.
2. Never attempt to repair a propane cylinder.
3. DO NOT allow children to play or tamper with propane cylinders.
4. When transporting, keep cylinder secured in an upright position with the cylinder valve turned off.
5. Store cylinders outdoors in a well ventilated and secure area.

Propane Gas is a heavier than air fuel that requires that basic safety precautions. Take the time to read the safety precautions in this manual and on the propane tank. Consult your propane supplier in regards to safety handling and transport of your propane tank.

The A270 heater comes equipped with a hose and regulator for connection to a standard 20lb propane cylinder. All fittings necessary to attach the hose/regulator to the heater are included. The propane tank is not included. Operating pressure is 11.0" W.C.

Propane Tank Requirements

A dented or rusty propane tank may be hazardous and should be checked by your propane gas supplier. Never use a cylinder with a damaged valve. Always check for leaks after every propane tank change.

The propane gas cylinder must be constructed and marked in accordance with the specifications for propane gas cylinders of the U.S. Department of Transportation (DOT) and designed for use with a Type 1 system only. DO NOT change the regulator/hose assembly from that supplied with the unit or attempt to use other types of tank connections.

Propane Tank Connections

Connect the Regulator to the tank (with the tank valve fully closed). Although the flow of gas is stopped when the Type 1 system is disconnected, you should always turn the propane tank main valve off after each use and during transport of the tank or heater. Insert the regulator inlet into the tank valve and turn the black coupler clockwise until the coupler is tight. **Do not over-tighten the coupler.**

To disconnect the coupler, first, make sure the main tank valve is turned off. Grasp the coupler and turn counter clockwise and the inlet will then disengage.

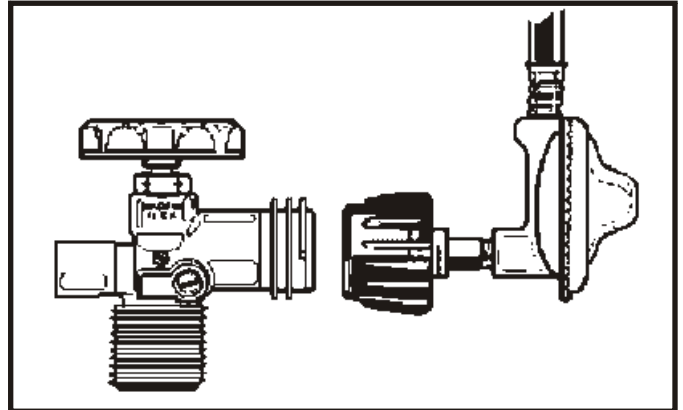

Test for Leaks

Leak tests must be performed with soapy water each time the tank is re-connected to the heater. Once the propane tank is connected open the tank valve. Apply soapy water with a spray bottle or small paint brush around tank valve and hose connections. If bubbles appear repair of the heater or tank is required before the heater is operated.

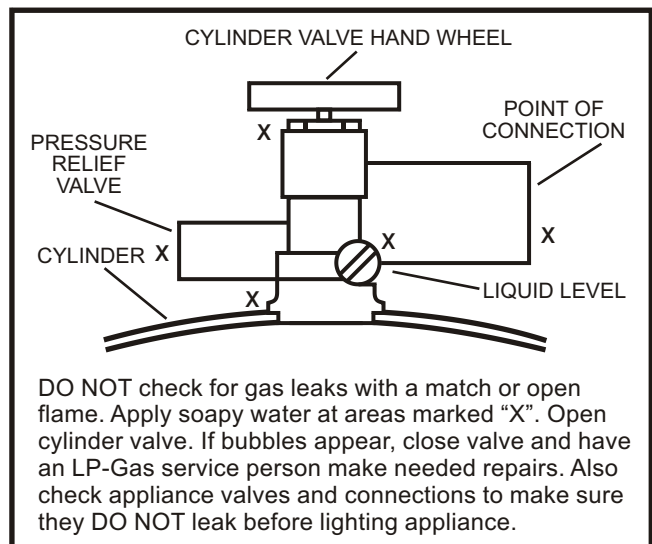

DO NOT check for gas leaks with a match or open flame. Apply soapy water at areas marked "X". Open cylinder valve. If bubbles appear, close valve and have an LP-Gas service person make needed repairs. Also check appliance valves and connections to make sure they DO NOT leak before lighting appliance.

Cylinders must be stored outdoors in a well-ventilated area out of the reach of children. If the appliance is stored indoors, the propane cylinder must be removed from the appliance and stored outdoors. DO NOT store a spare propane cylinder under or near this appliance. NEVER fill the cylinder beyond 80 percent full. For appliances designed to use a CGA No. 791 Connection. "Place the dust cap on the cylinder valve outlet whenever the cylinder is not in use. Only install the type of dust cap on the cylinder valve that is provided with the cylinder valve. Other types of caps or plugs may result in leakage of propane.

TEST FIRING HEATER

Test fire heater, following the lighting instructions on heater post. Leak test all gas connections with soapy water. Soap bubbles indicate gas leakage. Do **NOT** use a match to test for gas leaks.

WARNING: White smoke may appear around the emitter grid during the first minute of the initial firing.

TROUBLE SHOOTING

Problem	Possible Causes
Pilot won't light	<ul style="list-style-type: none">• Air in gas line• Low gas pressure• Gas line turned "Off"• Blockage in gas line
Pilot won't stay lit	<ul style="list-style-type: none">• Bad thermocouple• Corrosion of thermocouple contact• Bad Valvet• Wind exceeding 10 mph
Main burner won't light	<ul style="list-style-type: none">• No power• Low gas pressure• Blockage in orifice• Manual valve not in "On" position

Limited Warranty and Service

Heaters carry a 90-day commercial or one-year residential factory warranty. All heaters are stamped with the date of manufacture. In most cases, your dealer or sales representative will handle the warranty procedure for you. If there is no sales representative available, the heater head and regulator may be returned to the factory for repair. Warranty is limited to repair of heaters at the factory or replacement parts. Any work or repair of this heater must be performed by qualified service personnel. Infrared Dynamics will not be liable for any other expense to the customer, except as stated above.

To Light Pilot

Rotate control knob to "Pilot" position. Firmly depress knob for 30 seconds while lighting pilot through ½" dia. lighting hole above control. Pilot should remain lit.

NOTE: Allow 1½ minutes to purge air through pilot after connection with a new tank of propane gas.

To Turn Heater On

Turn control knob to "On" position.

To Turn Heater and Pilot "Off"

Turn knob to "Pilot" position. Depress slightly and turn to "Off" position. Wait 5 minutes after complete shutoff of heater before relighting pilot. Turn "Off" gas tank when heater is not in use.

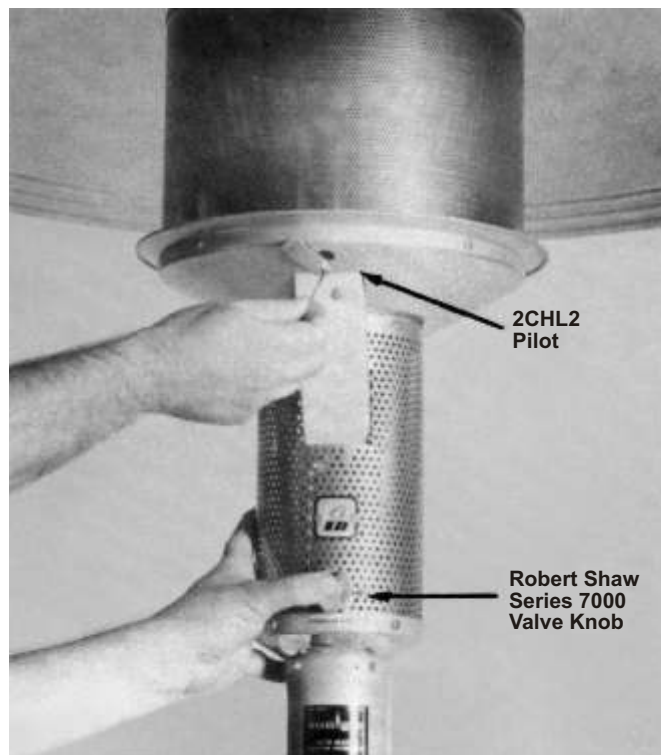

Manufactured by

INFRARED DYNAMICS, INC.

Yorba Linda, CA 92886 U.S.A.

Tel: (714) 572-4050 Fax: (714) 572-6093

Toll-Free: (888) 317-5255

www.infradyne.com